

SAE 8

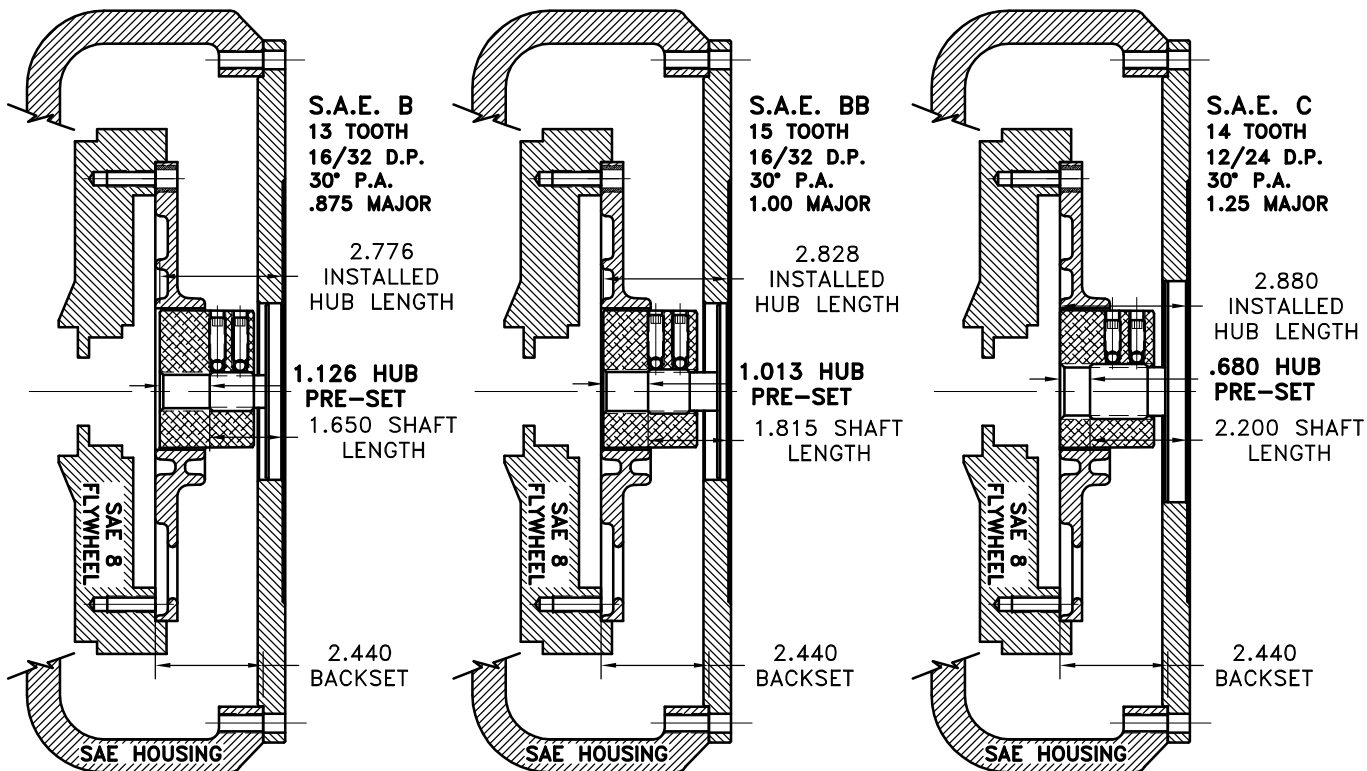

SET SCREW TORQUE: 20 FT.LBS.

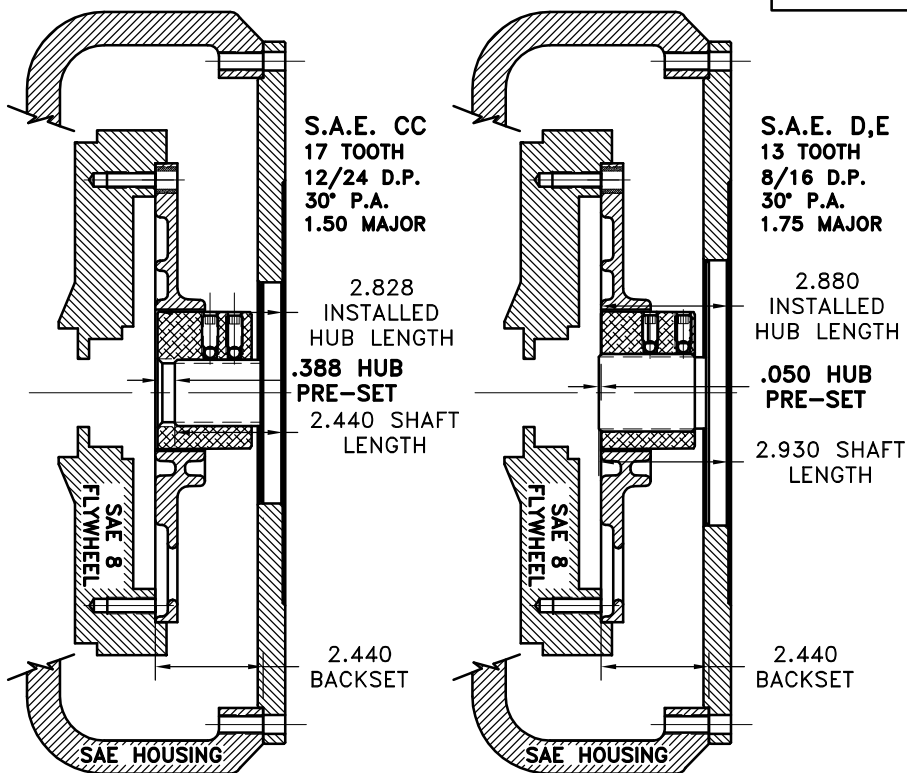

IMPORTANT INSTALLATION NOTE!!!!

THIS PRINT IS FOR LOCATION OF HUB ON SPLINED SHAFTS ONLY. IMPROPER INSTALLATION OF HUB COULD CAUSE PREMATURE WEAR AND OR FAILURE. IF YOU HAVE A SHAFT LENGTH OTHER THAN THOSE SHOWN HERE PLEASE CONTACT DISTRIBUTOR OR FACTORY FOR FURTHER INFORMATION. HUB SET SCREWS MUST BE PROPERLY TORQUED TO 20 FT.LBS. EACH. PLEASE CONTACT DISTRIBUTOR OR FACTORY FOR ANY FURTHER QUESTIONS.

THIS DRAWING IS THE PROPERTY OF HAYES MFG. INC. AND IS LOANED SUBJECT TO THE CONDITION THAT IT SHALL NOT BE REPRODUCED, COPIED, LOANED OR OTHERWISE DISPOSED OF, DIRECTLY OR INDIRECTLY. IT SHALL BE USED AS A MEANS OF REFERENCE TO WORK FURNISHED BY THIS COMPANY ONLY AND IS NOT TO BE SUBMITTED TO OUTSIDE PARTIES FOR EXAMINATION WITHOUT OUR CONSENT.

SYMBOLS	DET.	PART NUMBER	DESCRIPTION	QTY.
<ul style="list-style-type: none"> — FLATNESS — STRAIGHTNESS — ANGULARITY — SQUARENESS — PARALLELISM — CONCENTRICITY — TRUE POSITION — ROUNDNESS — CIRCULAR RUN OUT — TOTAL RUN OUT — CYLINDRICITY — FINISH 	<p>DO NOT SCALE DRAWING</p> <p>TOLERANCES UNLESS OTHERWISE SPECIFIED</p> <p>1/32" MAXIMUM</p> <p>ANGLE ±1/2°</p> <p>FRACTION ±1/32</p> <p>DECIMAL</p> <p>.00 ±.01</p> <p>.000 ±.005</p> <p>.0000 ±.0005</p>			
<p>— UNLESS OTHERWISE SPECIFIED —</p> <p>REMOVE FIRST THREAD ON ALL TAPPED HOLES</p> <p>BREAK ALL SHARP CORNERS .010 TO .020 STAMP OR MARK DRAWING NO.</p>			<p>TITLE</p> <p style="text-align: center; font-weight: bold;">SAE 8 HUB PRE-SET PRINT</p>	
	<p>DRAWN BY</p> <p>SIETING</p> <p>CHECKED BY</p> <p>RJH</p>	<p>DATE</p> <p>11-15-05</p> <p>SCALE</p>	<p>DRAWING NO.</p> <p style="font-size: 1.2em; font-weight: bold;">HPS-10</p> <p>SHEET OF REV.</p>	